

# MAINTENANCE PROCEDURES

## PREMIUM BALANCED DOOR

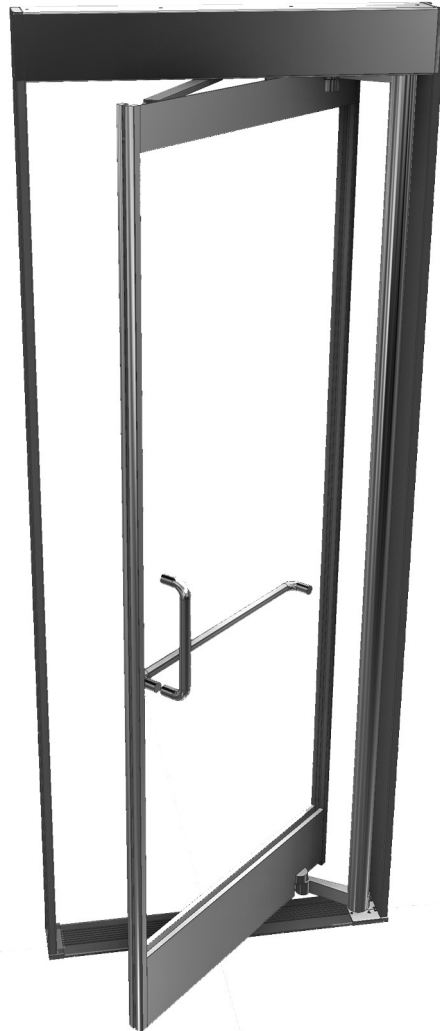

**NOTE TO INSTALLER:**  
THE PAWL TOOL AND HEX WRENCH REQUIRED FOR TENSION ADJUSTMENT  
SHOULD REMAIN WITH THE BUILDING OWNER OR MAINTENANCE DEPARTMENT.

**CRL**<sup>®</sup>

---

Phone: (800) 421-6144 • Fax: (800) 582-7501  
crlaurence.com • usalum.com • crl-arch.com

---

11M0227

# MAINTENANCE

Proper maintenance is critical to the life and operation of the Premium Balanced Door System. It is important to regularly clean environmental debris from areas adjacent to moving parts such as bearings, roller tracks, and gear assemblies.

**DO NOT LUBRICATE MOVING PARTS.** Each component is shipped from the factory with ample lubrication and if kept clean will provide a long service life. Compressed air, soft clean towels, and a small brush are recommended for most cleaning and maintenance procedures.

## BOLTS

(Quarterly)\*

Inspect and tighten all exposed Bolts and Screws. Vibration and movement over time will cause screws to loosen. Regular tightening will ensure proper door operation and prevent component damage.

## TOP PIVOT ARM

(Check Quarterly)\*

Wipe debris from arm and pivot block. Blow away any dirt between block and arm joint.

## DOOR GLASS

(Check Regularly)\*

Clean with conventional glass cleaners. Avoid build up of road grime and hand prints.

## TENSION ADJUSTMENT

(GEARBOX OR WORM GEAR)

(Check Regularly)\*

Blow away dirt. Brush or wipe grime away from surrounding area.

Dry excessive moisture.

## TOP ROLLER TRACK

(Check Quarterly)\*

Wipe dirt and debris from inside track with a damp cloth. Check for smooth operation.

NOTE: The top roller track (damper and cam plates) are manufactured from bronze alloy and are clear coated with a strippable material. Periodic refinishing may be required to maintain their original luster.

## WEATHERSTRIPS

(Check Monthly)\*

Blow dirt from pile and wipe off any excess moisture.

## BRUSHED STAINLESS

(Check Regularly)\*

Wipe down with a damp towel on a regular basis. Remove any build up of salt and road grime.

## BOTTOM PIVOT ARM

(Check Regularly)\*

Wipe debris from arm and pivot block. Blow away any dirt between block and arm joint.



\*Inspection intervals are suggestions. Inspection and maintenance should be based on actual cycle levels and environmental conditions.

# MAINTENANCE

Use the tension adjustment gearbox at the base of each hinge tube to adjust the closing force of the doors.

TENSION ADJUSTMENT GEARBOX  
RIGHT SIDE

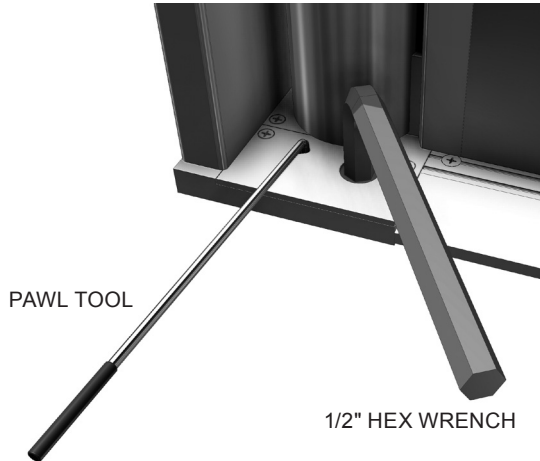

## ADJUSTING THE CLOSING FORCE

The closing force may require adjustment periodically due to changes in building pressure and temperature.

Use the Pawl Tool to release the force of the torsion tube spring. Pulling back on the Pawl Tool while holding the Hex Wrench allows the spring tension to relax in a controlled manner. Without the Hex Wrench in place the torsion spring will rapidly unwind to zero force.

Remove the Pawl Tool and use the Hex Wrench to ratchet up the torsion spring force to the desired level. For a right side gearbox, as illustrated, a counterclockwise motion will **INCREASE** the tube tension.

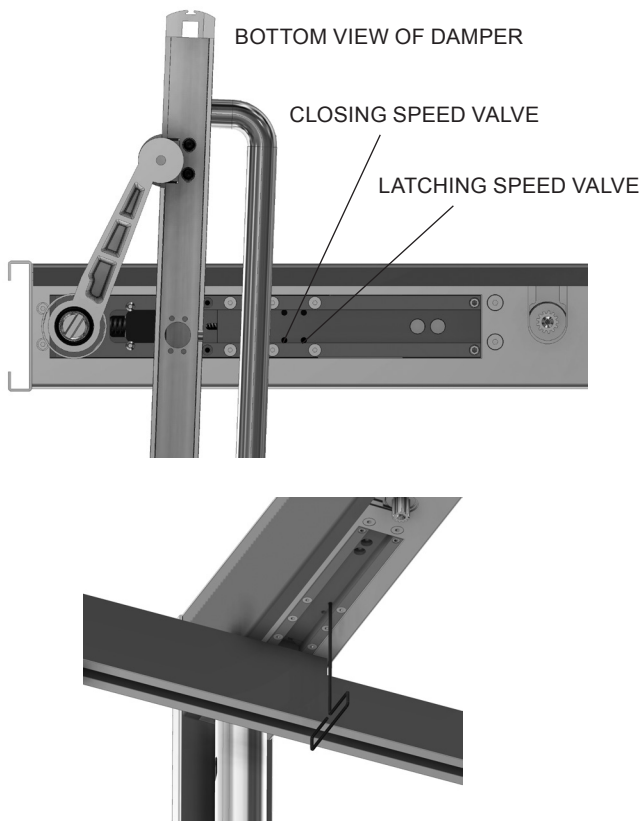

## ADJUSTING THE DAMPER SPEED

The damper is a two stage device that regulates the speed at which manual closing occurs. Gently open the valves until they stop turning (counterclockwise).

Do not force beyond a gentle stop.

Have an assistant open the door from the exterior side to the maximum position. Turn the closing speed valve 1/4 turn. While gently holding it to prevent slamming, let the door fully close two times. Repeat the procedure until the door closes at the desired rate of speed.

Repeating the same cycling procedure, close the latching speed valve until you see a noticeable speed drop at the last 10" -12" of travel. You may need to readjust the closing speed valve until you reach a desired overall performance. Each valve adjustment affects the other.

Optimum closing action requires a delicate balance between the closing speed, latching speed, and spring tension. Adjustment patterns will also vary from one door to another. Be sure to let the door cycle several times before changing the settings.

USE 5/16" HEX WRENCH TO ADJUST DAMPER VALVES.  
(TURN=COUNTERCLOCKWISE TO LOOSEN)

## MAINTENANCE

---

### CARE AND CLEANING OF STAINLESS STEEL

Satin polished stainless steel is one of the most durable and easiest finishes to maintain. Although stainless steel is generally resistant to corrosion, the surface is susceptible to cosmetic deterioration by the effects of salt water and air-borne chemicals which may result in small brown spots appearing on its surface (this process is likely to be accelerated in coastal areas). These spots in no way affect the strength, integrity or longevity of the product, they are simply superficial discolorations that require cleaning to restore the stainless steel to its original appearance.

Stainless steel finishes should be cleaned with rubbing motions in the same direction as the grain texture with a foam spray cleaner, such as **CRL Cat. No. CRL841** Stainless Steel Polish & Cleaner, which cleans, polishes, and protects stainless steel without hard rubbing and polishing. A coating of CRL841 resists fingerprints, grease and water splatter, and helps preserve the factory finish.

Wipe with a clean, dry cloth such as **CRL Cat. No. 1550** Lint-Free Glass Wipes, which are made with four plies of strong, white paper and reinforced in both directions with an extra ply of tough nylon. These highly absorbent rugged wipes will stand up to the most demanding shop work.

For repair of damaged finishes, satin stainless steel can be rubbed with the **CRL Cat. No. SB7447F** - 3M® Scotch-Brite™ Fine Pad.

Stainless steel finishes should be rubbed in the same direction as the grain texture.

For **LONG TERM PROTECTION** and use on **REPAIRED AREAS**, CRL offers an unsurpassed surface treatment system specifically designed to protect both glass and stainless steel.

**CRL 6K Hydrophobic Surface Protection** product is a two-step system.

Step One: **CRL Cat. No. PC6025** - 6K Pre-Clean Solution (250 ml bottle)

Step Two: **CRL Cat. No. 6K6025** - 6K Protect Formula (250 ml bottle)

Proper application of the 6K System will offer surface protection for up to three years.

Visit [crlaurence.com](http://crlaurence.com) for more details.

C.R. Laurence, Inc. warrants all products manufactured by it and supplied hereunder to be free from defects in material and workmanship in accordance to our contract.

This warranty shall not apply to any products not manufactured by CRL, nor to any products which have been repaired or altered by others without CRL's written consent. This warranty shall not include failure of parts and materials due to improper installation, inadequate support of surrounding structures, and/or lack of proper maintenance.